

Modular Cooking Range Line thermaline 90 - 4 Zone Induction Top on Oven, 2 Sides H=800

ITEM # _____

MODEL # _____

NAME # _____

SIS # _____

AIA # _____

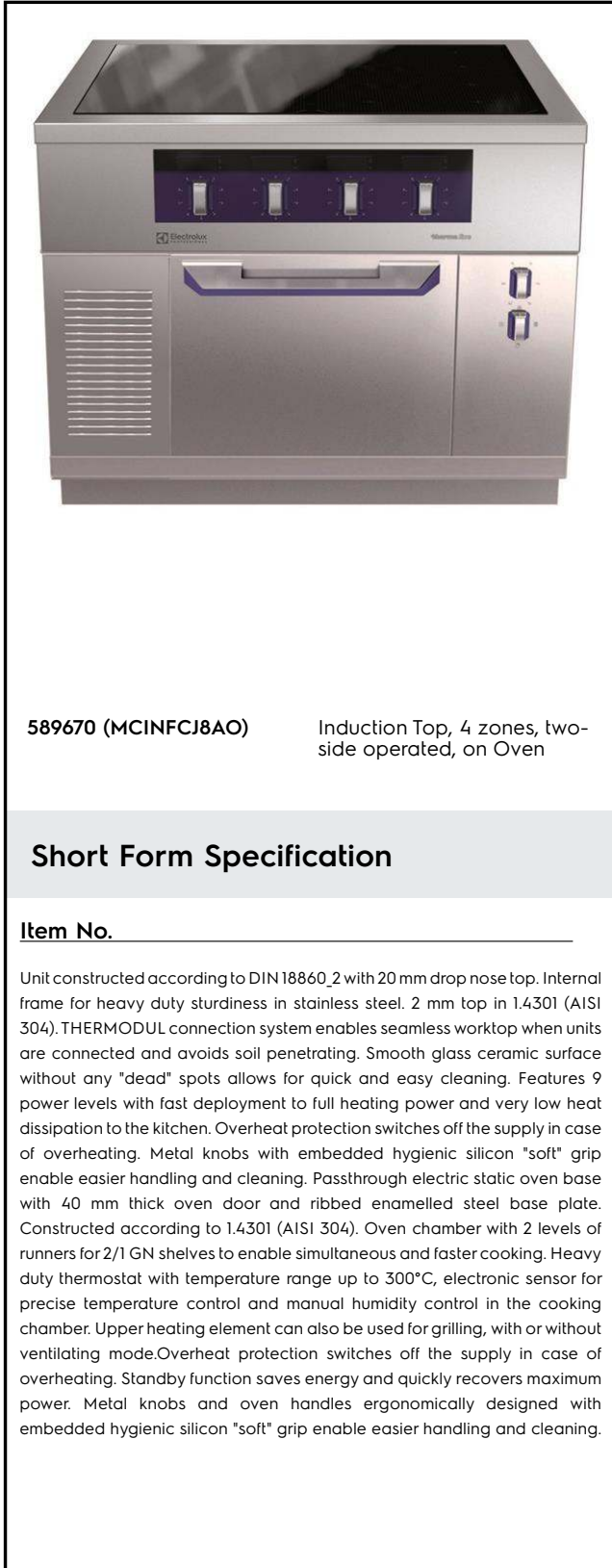
589670 (MCINFCJ8AO)

Induction Top, 4 zones, two-side operated, on Oven

Short Form Specification

Item No.

Unit constructed according to DIN 18860_2 with 20 mm drop nose top. Internal frame for heavy duty sturdiness in stainless steel. 2 mm top in 1.4301 (AISI 304). THERMODUL connection system enables seamless worktop when units are connected and avoids soil penetrating. Smooth glass ceramic surface without any "dead" spots allows for quick and easy cleaning. Features 9 power levels with fast deployment to full heating power and very low heat dissipation to the kitchen. Overheat protection switches off the supply in case of overheating. Metal knobs with embedded hygienic silicon "soft" grip enable easier handling and cleaning. Passthrough electric static oven base with 40 mm thick oven door and ribbed enamelled steel base plate. Constructed according to 1.4301 (AISI 304). Oven chamber with 2 levels of runners for 2/1 GN shelves to enable simultaneous and faster cooking. Heavy duty thermostat with temperature range up to 300°C, electronic sensor for precise temperature control and manual humidity control in the cooking chamber. Upper heating element can also be used for grilling, with or without ventilating mode. Overheat protection switches off the supply in case of overheating. Standby function saves energy and quickly recovers maximum power. Metal knobs and oven handles ergonomically designed with embedded hygienic silicon "soft" grip enable easier handling and cleaning.

Main Features

- Fast deployment with full heating power immediately.
- Low heat dissipation to the kitchen.
- Overheat protection: the temperature sensor switches off the supply in case of overheating.
- Pans can easily be moved from one area to another without lifting.
- The smooth glass-ceramic surface can be quickly and easily cleaned, thus providing maximum hygiene.
- All major components may be easily accessed from the front.
- THERMODUL connection system creates a seamless work top when units are connected to each other thus avoiding soil penetrating vital components and facilitating the removal of units in case of replacement or service.
- Metal knobs with embedded hygienic "soft-touch" grip for easier handling and cleaning. The special design of the controls prevents infiltration of liquids or soil into vital components.
- 9 power levels.
- Large visible digital display manufactured in tempered glass to resist heat and chemicals, showing temperatures or power settings. The display also shows on/off status of the appliance and on/off status of the heating elements.
- Unit constructed according to DIN 18860_2 with 70 mm recessed plinth.
- 40 mm thick oven door for heat insulation.
- Handles are ergonomically designed with silicon "soft" grip for easy handling and cleaning.
- Oven chamber to have 2 levels of runners to accommodate 2/1 GN trays and ribbed enamelled steel base plate.
- The upper heating element of the oven can also be used for grilling.
- Manual control of humidity in cooking chamber.
- Electronic sensor for precise temperature control.
- Oven temperature up to 300 °C

Construction

- Control light for each zone.
- 2 mm top in 1.4301 (AISI 304).
- Flat surface construction with minimal hidden areas to easily clean all surfaces
- Unit constructed according to DIN 18860_2 with 20 mm drop nose top.
- Unit constructed according to DIN 18860_2

APPROVAL: _____

with 20 mm drop nose top and 70 mm recessed plinth.

- IPX5 water resistance certification.
- Internal frame for heavy duty sturdiness in stainless steel.

Sustainability



- Standby function for energy saving and fast recovery of maximum power.
- This model is compliant with Swiss Energy Efficiency Ordinance (730.02).

Included Accessories

- 1 of Grid, chromium plated, for ovens PNC 910652 2/1 GN

Optional Accessories

- | | | |
|--|------------|--------------------------|
| • Scraper for cook tops | PNC 910601 | <input type="checkbox"/> |
| • Baking sheet 2/1 GN for ovens | PNC 910651 | <input type="checkbox"/> |
| • Fire clay plate 2/1 GN for ovens | PNC 910656 | <input type="checkbox"/> |
| • Connecting rail kit, 900mm | PNC 912502 | <input type="checkbox"/> |
| • Stainless steel side panel, 900x800mm, freestanding | PNC 912511 | <input type="checkbox"/> |
| • Portioning shelf, 1000mm width | PNC 912528 | <input type="checkbox"/> |
| • Stainless steel front kicking strip, 1000mm width | PNC 912600 | <input type="checkbox"/> |
| • Stainless steel side kicking strips left and right, freestanding, 900mm width | PNC 912621 | <input type="checkbox"/> |
| • Stainless steel plinth, freestanding, 1000mm width | PNC 912922 | <input type="checkbox"/> |
| • Connecting rail kit: modular 90 (on the left) to ProThermetic tilting (on the right), ProThermetic stationary (on the left) to ProThermetic tilting (on the right) | PNC 912975 | <input type="checkbox"/> |
| • Connecting rail kit: modular 80 (on the right) to ProThermetic tilting (on the left), ProThermetic stationary (on the right) to ProThermetic tilting (on the left) | PNC 912976 | <input type="checkbox"/> |
| • Endrail kit, flush-fitting, left | PNC 913111 | <input type="checkbox"/> |
| • Endrail kit, flush-fitting, right | PNC 913112 | <input type="checkbox"/> |
| • Back panel, 1000x550mm, for bases one-side operated | PNC 913184 | <input type="checkbox"/> |
| • Endrail kit (12.5mm) for thermaline 90 units, left | PNC 913202 | <input type="checkbox"/> |
| • Endrail kit (12.5mm) for thermaline 90 units, right | PNC 913203 | <input type="checkbox"/> |
| • Insert profile d=900 | PNC 913232 | <input type="checkbox"/> |
| • Side reinforced panel only in combination with side shelf, for freestanding units | PNC 913259 | <input type="checkbox"/> |
| • Shelf fixation for TL90 two-side operated | PNC 913284 | <input type="checkbox"/> |
| • Filter W=1000mm | PNC 913666 | <input type="checkbox"/> |
| • Stainless steel dividing panel, 900x800mm, (it should only be used between Electrolux Professional thermaline Modular 90 and thermaline C90) | PNC 913673 | <input type="checkbox"/> |
| • Electric mains switch 63A 10mm ² NM for modular H800 electric units (factory fitted) | PNC 913677 | <input type="checkbox"/> |

- Stainless steel side panel, 900x800mm, flush-fitting (it should only be used against the wall, against a niche and in between Electrolux Professional thermaline and ProThermetic appliances and external appliances - provided that these have at least the same dimensions)

PNC 913689

Front

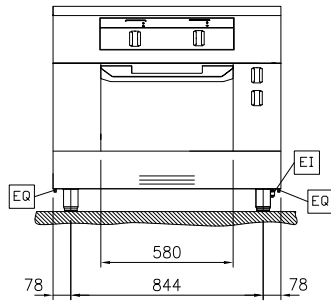

Side

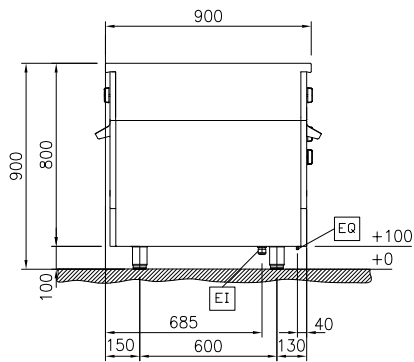

EI = Electrical inlet (power)
EQ = Equipotential screw

Top

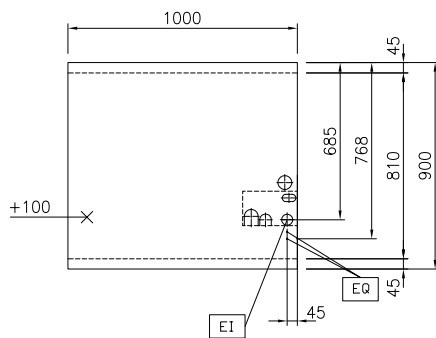

Electric

Supply voltage: 400 V/3N ph/50/60 Hz
Total Watts: 25 kW

Key Information:

External dimensions,
Width: 1000 mm
External dimensions,
Depth: 900 mm
External dimensions,
Height: 800 mm
Net weight: 197 kg
Configuration: On Oven,Both-Sides
Operated
Front Plates Power: 5 - 5 kW
Back Plates Power: 5 - 5 kW
Front Plates dimensions: 320x330 320x330
Back Plates dimensions: 320x330 320x330
Induction Top Dimensions
(width): 1000 mm
Induction Top Dimensions
(depth): 900 mm

Sustainability

Current consumption: 39.7 Amps